



TI-CADS

Content Acquisition and Distribution System

Mirko Škrbić Ph.D.
mirko.skrbic@teleinformatica.ba
www.teleinformatica.ba

Content Acquisition and Distribution Support Centers

- The role of the centers is to support Content Acquisition, production and Distribution for TV, radio and new media platforms.
- Teleinformatica has developed TI-CADS, a combination of Contact Centers and Media Servers for streaming and VoD.
- TI CADS supports IPTV, iTV, VoIP, SMS, E-mail, Web, WAP, USSD and Fax communication.
- They have been developed to support very high traffic volumes with hundreds of operators posts, powerful IVR (including Text to Speech and Speech to Text) and storage capacities.
- Every contact type is registered to the Data Base and tied with all previous records of the customer.

The IPTV Opportunity

- **The cost to deliver video streams to the home has fallen dramatically with new technology**
- **Advanced Video Codecs reduce transmission, storage and server cost by 2X over MPEG-2 and make high-definition streaming practical**
- **Open standards have accelerated innovation and will ensure a competitive environment**
- **IPTV will drive revenue and subscriber retention, adding**
- **significant value beyond basic Internet broadband**

IPTV Key Ingredients

- **Virtual Private Streaming enables to serve each subscriber a customized video stream**
- **Advanced Video Codecs reduce transmission, storage and server cost by 2X over MPEG-2 and make high-definition streaming practical**
- **Open standards accelerate innovation and will ensure a competitive environment**

IPTV will drive revenue and subscriber retention, adding significant value beyond basic Internet broadband service

The Basic Configuration of TI- CADS Center

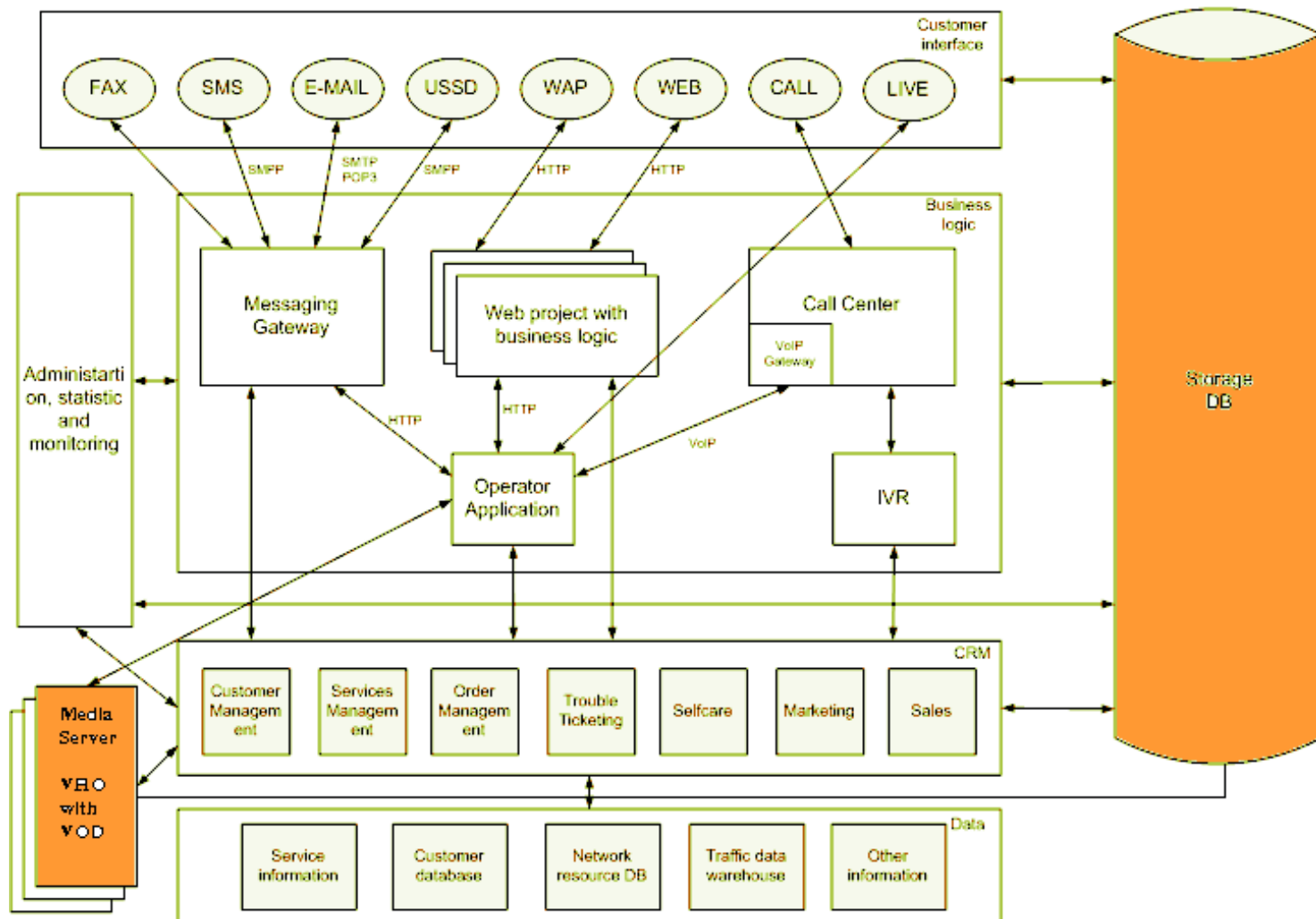

The most compelling combination is TV because of enormous consumer base

Interactive TV : Definition

- It is not
 - Digital TV and Set Top Boxes
- What it is
 - Providing two way communication between the viewer and the broadcaster (or between multiple viewers)
 - Technology Independent

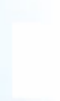
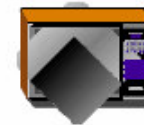

Typical Applications

- **SMS Voting**
- **Music dedication programme - Audio/Music on Demand (MoD) – either streaming or pushed/download to play**
- **IPTV gaming**
- **IPTV Picture management**
- **IPTV directory service (local yellow pages)**
- **One feature is the acquisition of amateur music or video clips through e-mail or web channels.**
- **Cooperation with professional producers companies is of high importance for high quality content production.**

The IPTV Production and Distribution

- **IPTV is most suitable form of TV for interactive content production and distribution.**
- **Appart to existing servers used in the contact center the IPTV VHO is integrated to provide IPTV production and distribution.**
- **It enables, among others, contact to all Internet users for content acquisition and distribution. Most attractive is Video on Demand service.**

General IPTV structure

CADS in a Role of VHO

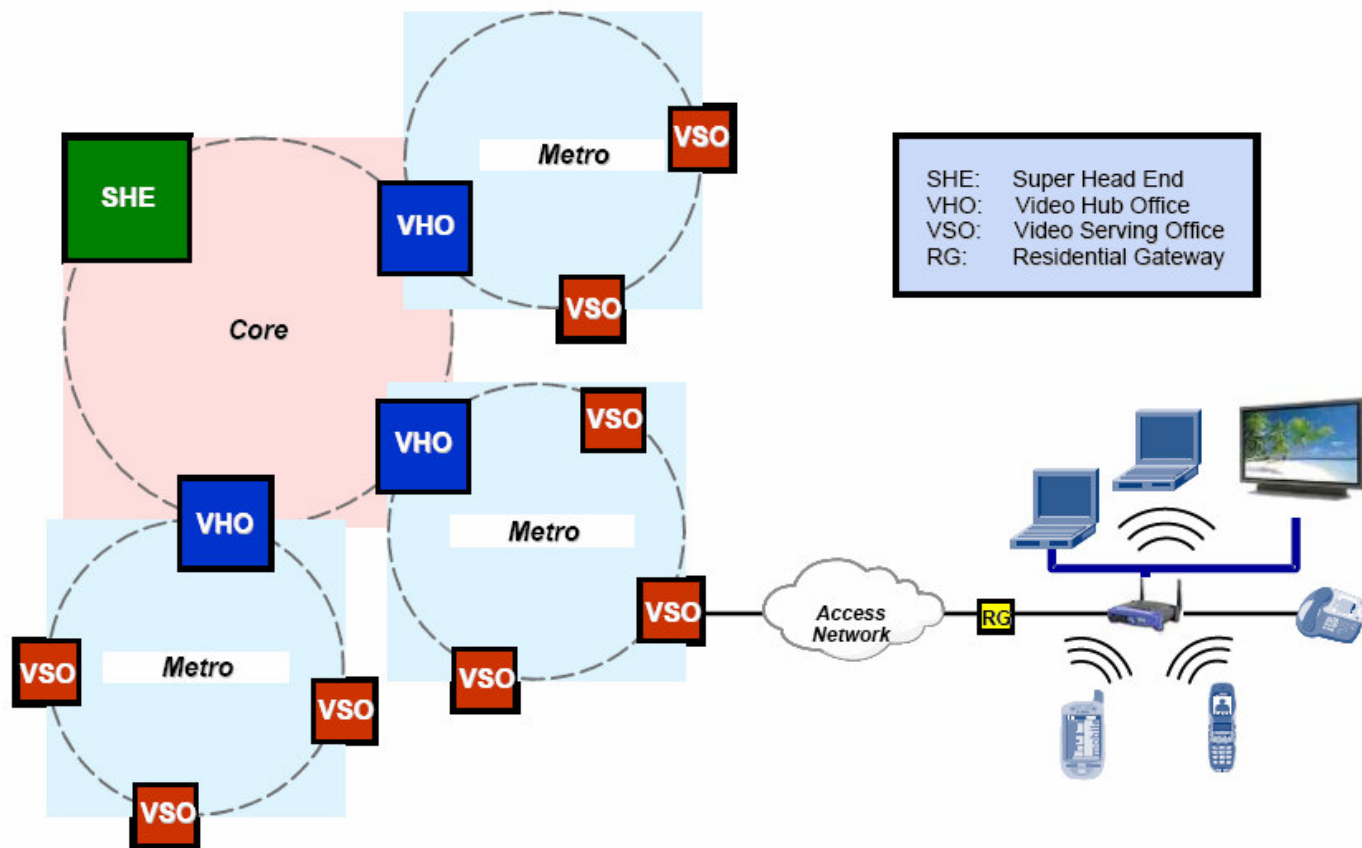

TI-CADS VHO part

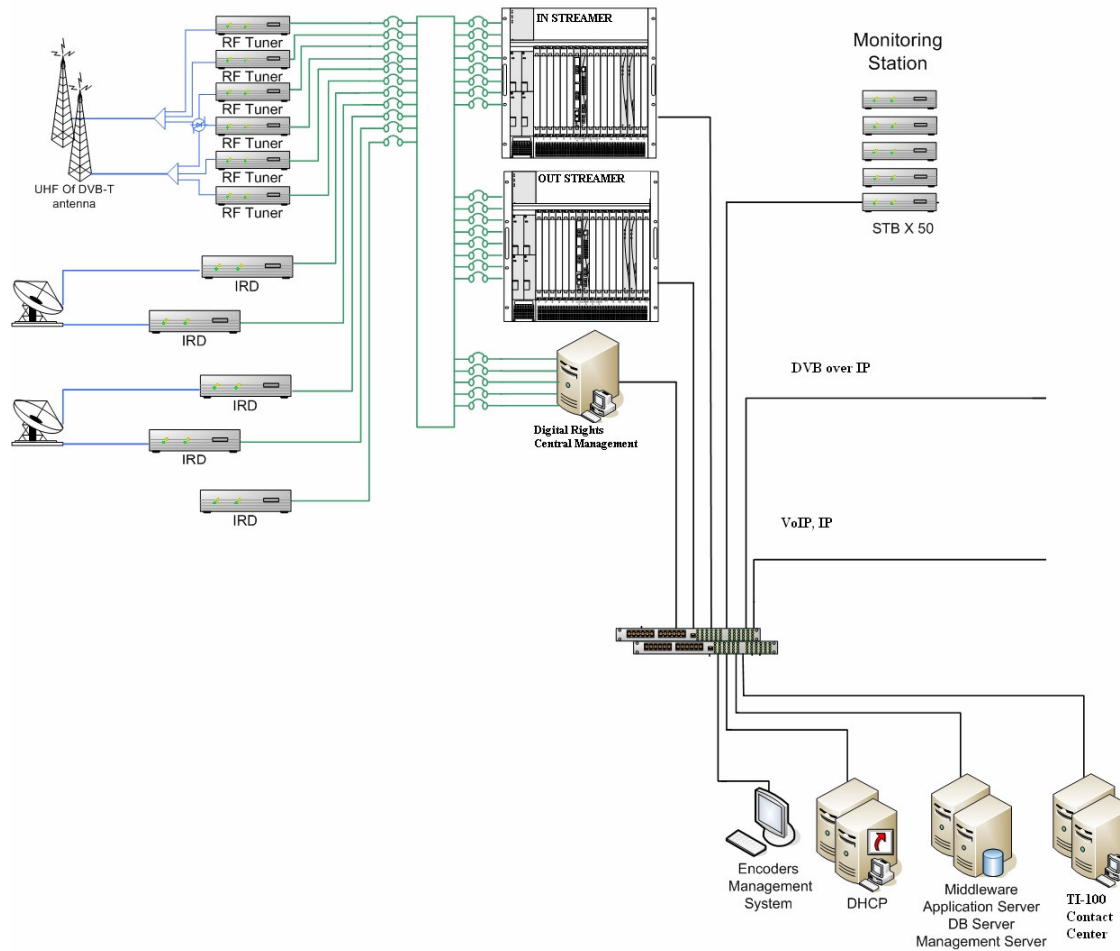

TI-CADS VSO part

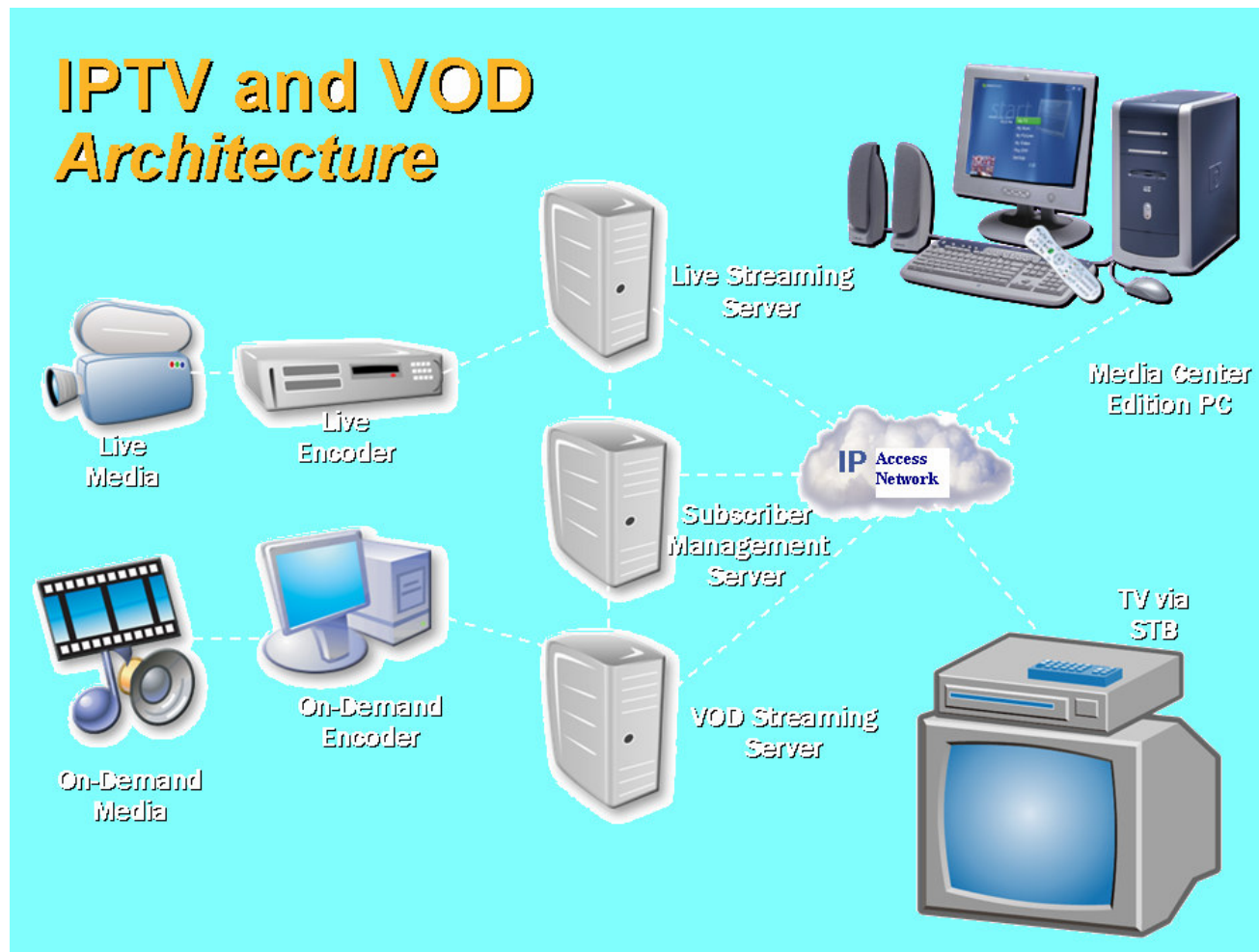

Two Level IPTV hierarchy - CADS in a Role of VHO

- **Video Hub Office (VHO)** - the video distribution points within a demographic market area (DMA) National content is received from each SHE. Local content is acquired and encoded. VOD servers and other application servers typically located in the VHOs. Insertion of local advertising is also performed in the VHO. TI-CADS is complete VHO.
- IPTV services are provided from the VHO via the aggregation/access network.
- **Video Serving Office (VSO)** - contains/hosts all access systems used to connect the TI-100 softswitches (a VSO assumed to be a Central Office) to the subscribers. In addition, the VSO contains aggregation equipment to enable efficient and reliable interconnection to the VHO.

DVB over IP a key element of TI-CADS

- **By the end of 2006 ETSI has issued standards ETSI TS 102 005, ETSI TS 101 154 and ETSI TS 102 154 treating the use of Video and Audio Coding in DVB services delivered directly over IP protocols**
- **Teleinformatica has applied those standards in communications between VHO and VSO**
- **Typical VHO capacity is 50 000 subscribers and typical VSO capacity is 250 subscribers. Unicast is preferred.**
- **The Operation and Maintenance, including Digital Rights management is done from the VHO, but it can be done from single national center for many VHO regions, thus playing just OEM role of Super Headend (SHE)**

Multicast can be supported but it has its weaknesses

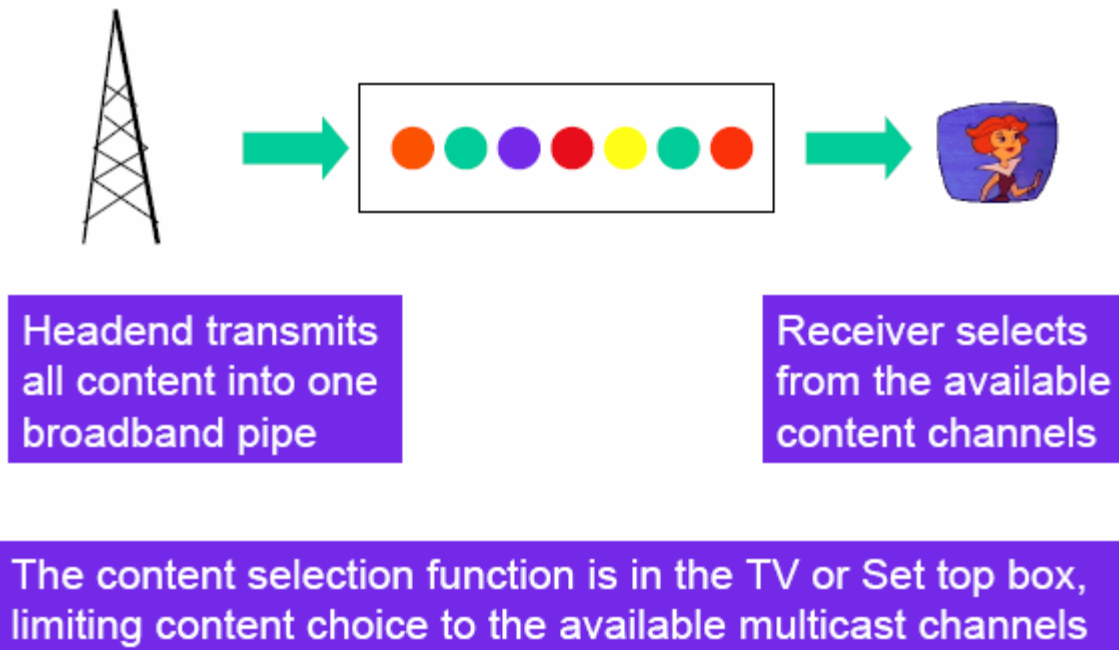

Unicast (Virtual Private Streaming)

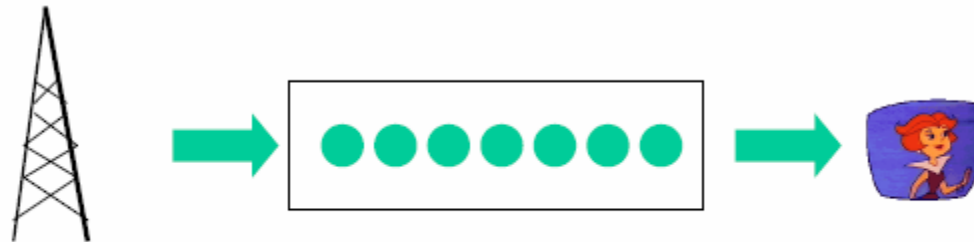

Headend offers unicast streaming from content vault

Each Receiver selects one content channel at a time

The content selection function is moved upstream, which enables unlimited amount of content that can be offered

A Unicast network offers unlimited content private streams and can emulate a Multicast network but not vice versa

Multicast vs Unicast Comparison

Multicast	Unicast
-----------	---------

- **Bandwidth is proportional to the number of channels**
- **Private streams adds to the required standard bandwidth**
- **Hundreds of Video Channels (limited by available bandwidth)**

- **Bandwidth is proportional to the number of receivers**
- **Private streams take required standard bandwidth**
- **Unlimited Content**
- **(only limited by size of storage vault)**

What about Unicast Cost?

- **The technology cost to deliver unicast streams has declined to low double-digit per stream**
- **A unicast settop box is significantly cheaper than a multicast settop box with PVR**
- **The networking bandwidth for pure unicast is also lower than for multicast with PVR**
- **As a result, it is simpler and cheaper to build a unicast IPTV network**

More importantly, Unicast offers superior ROI

Unicast is where Revenue

- **Movies on Demand**
- **Television on Demand**
- **Relevant Video Advertising**
- **Membership Video Content**
- **Local and Regional Content**
- **Educational and Instructional Video**
- **Fine-grained Parental Access Control**

Unicast enables video services that drive both customer acquisition and retention and are not feasible with satellite

TI- CADS VOD

- **IPTV Video on Demand (VOD)** - The Video on Demand service enables TV viewers to select TV videos from a central repository for viewing on a television at their desired time. VOD systems are either “streaming VOD” or “push VOD”:
 - Streaming VOD is VOD in which rendering on the display device/viewing can (simultaneously) start as (or at least overlaps with) the video distribution over the network
 - Push VOD is VOD in which the program is brought in its entirety to a set-top box before viewing starts (it can either be invoked by the viewer or by the operator without an explicit viewer request). The operator based option is more likely in the beginning.

TI-CADS Business Case

1. Subscriber on DSL CO line calls short VOD number or sends ans SMS requiring particular video content
2. Operator responds and starts AAA procedure
3. Unicast streaming started
4. Help and other support if needed

Examples of VoD work Support Centers – how it will work?

- PPV (Pay Per View) - an offering of pay-television broadcasts to customers in a manner that they can buy a particular program event separately from any package or subscription.
- The program event is shown at the same time to everyone ordering it.
- PPV Purchase can be done via:
 - a phone call to contact an automatic response unit (ARU) utilizing automatic number identification (ANI)
 - a phone call to customer service representative (CSR)
 - filling and sending a form in an Internet web site
 - filling and sending a form on an interactive TV e.g., on an electronic program guide, using the remote control.

What is advantage of this solution compared to traditional selection IPTV and VOD services?

- It is an addition to the on TV menu. It gives support to iTV and support to customers during operation. TI-CADS can receive, through web or mail channels, amateur video and organize different shows based on it.
- But most important role of VHO is regional Content Aggregation and Management. The success of TV business depends mostly on high quality local programs that are easily sold in the country or abroad. The old analog content should be acquired from different sources and conditioned.
- All regional content should be conditioned, that means digitization and production of meta files for wholesale exchange and billing.
- TI-CADS centers should give full technical support to creative people doing TV programs. They are key to success of the business.

The Conclusions

- **TI-CADS centers are universally applicable to support different TV business platforms.**
- **They have plenty of tools to support the other business schemes, like TV screen menu driven VoD, as an supplement.**
- **TI-CADS enables new inovative services, as a kind of service development and application platform.**
- **It is based on open standards, so that newly developed equipment of different vendors can be integrated.**
- **It gives a helping hand to creative TV people to be ahead competition.**

Thank you!